



stairCare
lifting the quality of life

HARMONY HOMELIFTS

Restricted to the ground floor of your home?

Regain the freedom of your home by being able to travel between floors smoothly, quietly and safely either seated in our Harmony Compact model or in one of our wheelchair carrying models.

The installation of a through floor lift is a far less complicated operation than you might think. Following the initial survey and the subsequent decision to proceed, our experienced team will carry out all necessary preparatory work and install the lift in four to five days providing this is one continuous process.

Sometimes space is limited, therefore the wheelchair Harmony range features an ingenious car design resulting in a wheelchair lift which is only fractionally larger on the outside than the inside. We are the market leaders when it comes to internal car size and the number of lift models available. The Harmony Longer Wider (LW) model is the largest lift car with a footprint less than 1055 x 1465 and can accommodate ALL category A and B wheelchairs.

For people who do not use a wheelchair, the Harmony Compact seated model requires just two thirds of the space of the standard Harmony.

Operation is simple. Having called the lift from the easily accessible wireless wall control (with no unsightly plastic trunking), sited to suit the user, the car door can be opened by the same control. The low integral ramp allows easy wheelchair access and a push button inside the car closes the door. A push of the car control button (which can be positioned by the user to suit their needs - not available on the Compact model) will signal the car to travel to the other floor, automatically lifting or replacing the aperture ceiling panel en route, where the reverse procedure is followed to exit the car.



Harmony allows you to move between floors smoothly and safely. Can be used with or without your wheelchair. Fold-up seat available.



Harmony Compact at lower level with fixed seat.



Lower room when lift upstairs



Upper room when lift downstairs



Entering the lift upstairs

Both lift-up aperture infill and car underpan are designed to provide a minimum half hour fire protection and both are fitted with smoke and intumescent fire seals. Pressure sensitive safety surface is incorporated in the floor aperture infill which will stop the lift if it is obstructed.

Interfloor aperture infill lifted automatically by the lift car

Safe edge around upper edge of car to stop lift if obstructed

The lift is fitted with automatic door interlocked to the car

Powered door on wheelchair model



Adjustable lift car controls can be positioned on the left or right of the car to suit users needs

Toughened safety glass windows which do not scratch like plastic

A steel liner is fitted into the floor aperture to provide a sealing face for both aperture infill and underpan



Harmony wheelchair model: optional grab handles can be fitted to suit the user

Optional modern LED's which spill light into the car and into a dark room

Pressure sensitive safety underpan doubles as ceiling closure and fire / smoke seal

No unsightly hydraulic ram on show (concealed in guide)

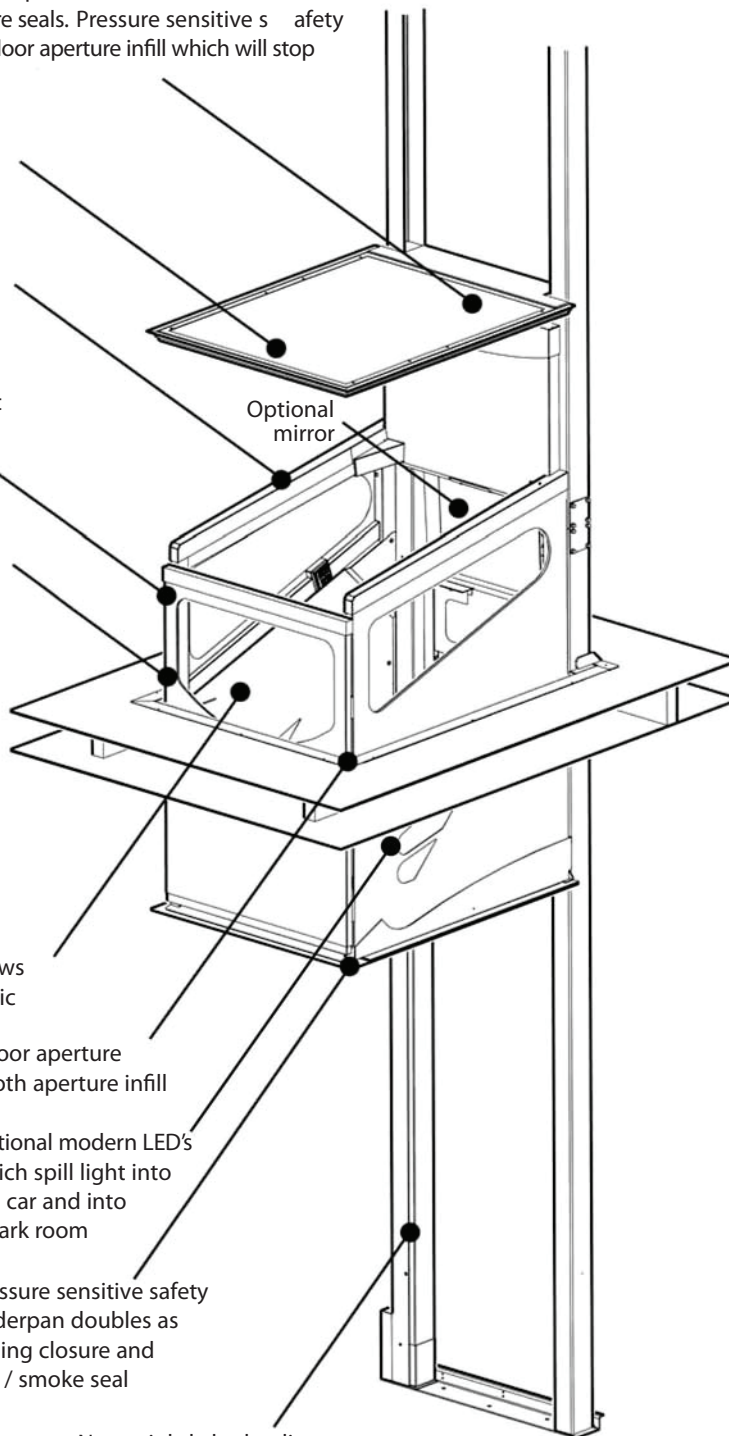

Moving downstairs



Lift approaching lower floor



Exiting the lift downstairs

State of the art hydraulic drive system provides the following benefits:

- Exceptionally smooth and quiet operation by virtue of remote power unit
- Inherent safety system to guard against free fall of car
- Flexibility of installation - minimal headroom required in first floor room and guides can be installed across windows or against non-load bearing walls

Standard features are as follows:

- Half hour fire integrity maintained in ceiling/floor irrespective of whether lift is parked upstairs or downstairs. Manufactured and tested to BS 5900:2012. Warrington Fire Research Centre assessment WF 320925
- The longer wider model will accommodate all category A & B wheelchairs
- Radio wireless controls in car and at both floors which enable travel, stop and door open/close commands. No unsightly surface trunking
- Powered door available on wheelchair models
- In the event of a power failure, a battery back up system allows operation of the lift car in the down direction by normal controls with all safety systems in operation
- Low floor car construction ensuring easier wheelchair access and egress with a 1:8 gradient
- The only lift available in the UK market that is fully compliant as standard with the Chartered Institute of Building Services Engineers (CIBSE) Guide D recommendations and BS5900:2012
- Fire sealing and fire protection including smoke detection to BS5900:2012

* Please note – The lift car styling shown in this brochure is available on all models except for the Harmony C model. Please contact us if you require further information.

Available options:

- Folding seat in wheelchair version (can also be used as a perch seat): 330mm W x 390mm D. Standard height 500mm from top of seat to floor (can be adjusted) maximum user weight 125kg
- A telephone can be fitted in the lift car
- A range of trim colours
- Mirror
- Hand held remote control
- Joystick control
- Grab handles
- Car padding (3 sides and door, all below glass)
- Up to 5 year warranty
- Left or right door handing
- The lift car side panels can be fitted with modern LED lights which switch on to emit a spill of light inside and outside of the car

Harmony 'S' Wheelchair Car Details

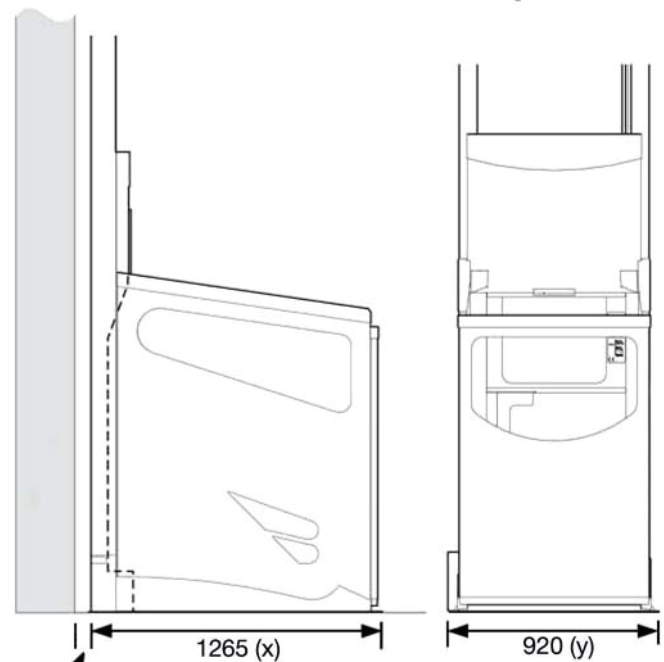

50mm min' recommended

All dimensions in mm

Travel: From 2060mm to 3650mm

Lift Model	Internal Width	Internal Length	External Width (y)	External Length (x)	Capacity
Harmony C* (Compact)	560	680	710	915	150kg
Harmony S (Std wheelchair)	755	1175	920	1265	280kg
Harmony W (Wider)	890	1175	1055	1265	280kg
Harmony L (Longer)	755	1375	920	1465	250kg
Harmony LW (Longer Wider)	890	1375	1055	1465	250kg

All dimensions in mm

